

Nussbaum



STOREPARKER N2202

We create parking space!

Dependent parking and intermediate storage
of vehicles and vans for up to 3.000 kg

Suitable for car dealerships, car rental areas, private car parks and car repair workshops



The hydraulic Parking System "Storeparker N2202" is used for Indoor and Outdoor operation to double the number of space on its original size. The system is placed above ground, without pit.

The STOREPARKER N2202 at a glance:

- dependent parking on 2 levels, ohne Grube
- platform above is horizontal accessible, below without platform - the lower parking levels is directly at the ground
- great solution for intermediate storage of vehicles up to 3.000 kg
- flexibel through different variants on system heights
- low requirements on the ground surface
- disassembly and installation on a new site possible
- available for Indoor and Outdoor operation
- modular placement, the segments are placed next to each other
- up to 100% more parking space
- for permanent users only

WIDTH DIMENSIONS	Special*	Standard	Comfort
Width per space (cm)	214	230	250
System width / single unit (cm)	259	275	295
System width / raster outer (cm)	252	268	288
System width / raster inner (cm)	244	260	280

All measures are maximum dimensions. *Special: Does not comply with the German garage regulations.

Calculation of total width: number of raster outer + number of raster inner = total width
Using the example of 5 systems: 2x 252cm + 3x 244cm = 1236cm



TECHNISCHE DATEN	2.5 Low	3.0 Low	2.5 High	3.0 High	2.5 Van	3.0 Van
Lifting capacity (kg)	2500	3000	2500	3000	2500	3000
Column height (cm)	320	320	353	353	466	466
Platform length (cm)	418	418	418	418	418	418
Clear bottom height (cm)	176	176	212	212	287	287
CHB = Car-height below (cm)	170	170	205	205	280	280
CHA = Car-height above (cm)	150*	150*	150*	150*	150*	150*
System height CHB + CHA (cm)	340	340	375	375	450	450
Engine power (kW)	3,0	3,0	3,0	3,0	3,0	3,0
Electrical power supply	3 PH+N+PE 400 Volt/50 Hz	3 PH+N+PE 400 Volt/50 Hz	3 PH+N+PE 400 Volt/50 Hz	3 PH+N+PE 400 Volt/50 Hz	3 PH+N+PE 400 Volt/50 Hz	3 PH+N+PE 400 Volt/50 Hz

All measures are maximum dimensions. *The car-height above is dependent on the available clear height at the site.



Modular, mobile and flexibel

Modular placement

The systems are built modular. I.e. the first segment consists of one primary column with lifting carriage and platform. Each further segment is arranged in the same principle. The last segment finalize with an end column.

Mobile parking

The system can be dismantled quickly and set up in another location with ease.

Low requirements on the ground surface

With low requirements on the ground surface the system offers a high flexibility at the choice of location. The floor plate should be covered for a minimum load of 30 N/cm, system forces see page 6.

Simple installation through "pre-assembled" delivery

The systems are delivered "pre-assembled" per segment. The platforms are complete and only to be connected with the machine columns, incl. column foot. Electrical and hydraulic connections must be attached.

The hydraulic connections between the two separate located segments, must be connected with hydraulic pipes, which will be adapted on the spot. For other connections, only pre configured pipes will be used; installation through the integrated channels of the basic construction.

The electrical installation between the two separate located segments has to connect with the vacant pipes. For all other connections, the electrical wiring must be installed through the integrated channels of the basic constructions.

LIFTPARKER MOBIL

- dependent parking, without pit
- 2 parking levels
- the Parking System has one horizontal platform above, below without platform – the vehicles are parked directly at the ground
- for a platform capacity of up to 3.000 kg
- different variants on system height and width per parking space available
- for permanent users
- modular placement, several segments are placed next to each other
- mobile concept, disassembly and installation on a new site possible
- low requirements on the ground surface
- quick time of installation
- operation via key-switch in dead man's control

Features – in the scope of supply

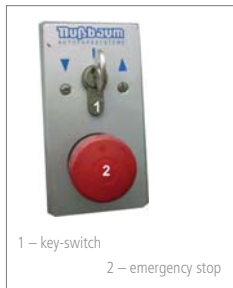

Key switch

Key switch incl. emergency stop, dead man's control type with brief operating instructions and wiring to hydraulic unit.



Hydraulic unit



Hydraulic unit "Silencio" with tubing and wiring to the installation. The oil submerged motor "Silencio" is extremely quiet and smooth running. The motor-pump assembly is sound absorbent.

We recommend, according to the access times, to use max. 10 segments with one hydraulic unit.

Location

According to the local requirements – preferable placed near the rear columns/ cylinders

Dimensions LxWxH

Hydraulic unit: ca. 60 cm x 22 cm x 40 cm
Switch cabinet: ca. 60 cm x 22 cm x 80 cm

Scope of supply

System with column(s), lifting platform and 2 lifting carriages. Completely with hydraulic driving elements and electrical control elements.

Width of parking space

Width of parking space 230 cm and vehicle weight 2500 kg as standard

Safety devices

- lockable main switch
- operate over the key switch (lifting, lowering): protection against unauthorized use
- emergency stop switch: protection against imminent danger
- pressure control valve: protection against over pressure of the hydraulic system
- plug protection for the lifting platform above
- chains for synchronization on the right and left side
- ground stripes for safe distance

Protection against corrosion

The substructure and the side carriers of the platform are zinced; the zinc-thickness is on both sides 275 g/m². This corresponds to a layer thickness of at least 20 μm acc. to EN 10142/10143.

The side carriers, the columns and the carrier for the key-operated switch are powder-coated, with RAL 7016, anthracite coal-grey.



Driving plates

Alu-bulb-plate even more user friendly when going and cruise the system.



Extra equipment – delivered as an option



Roofing

The roof protect against solar radiation and is a visual eye-catcher. The roof can be fixed directly on the columns of the system



Ramp

As an additional support to drive on the upper lifting platform a ramp can be provided when required.

Width of parking space

Width of parking space 214cm and 250cm

Vehicle weight

Optional vehicle weight: up to 3000kg

Additional sound insulation

structure-borne noise package to comply with DIN 4109 and adherence to sound insulation-measure R_w '57 sound insulation hood to minimize airborne sound

Protection against corrosion

Corrosion protection version "Premium" of driving plates by individual piece-galvanizing to DIN ISO 1461

Corrosion protection version "Premium Plus" of driving plates by individual piece-galvanizing to DIN ISO 1461 and coating of the top surfaces

Tips

We recommend a maintenance contract. Attendance and cleaning according to recommendations or in regular intervals.

Technical information

Foundation forces (loading points)

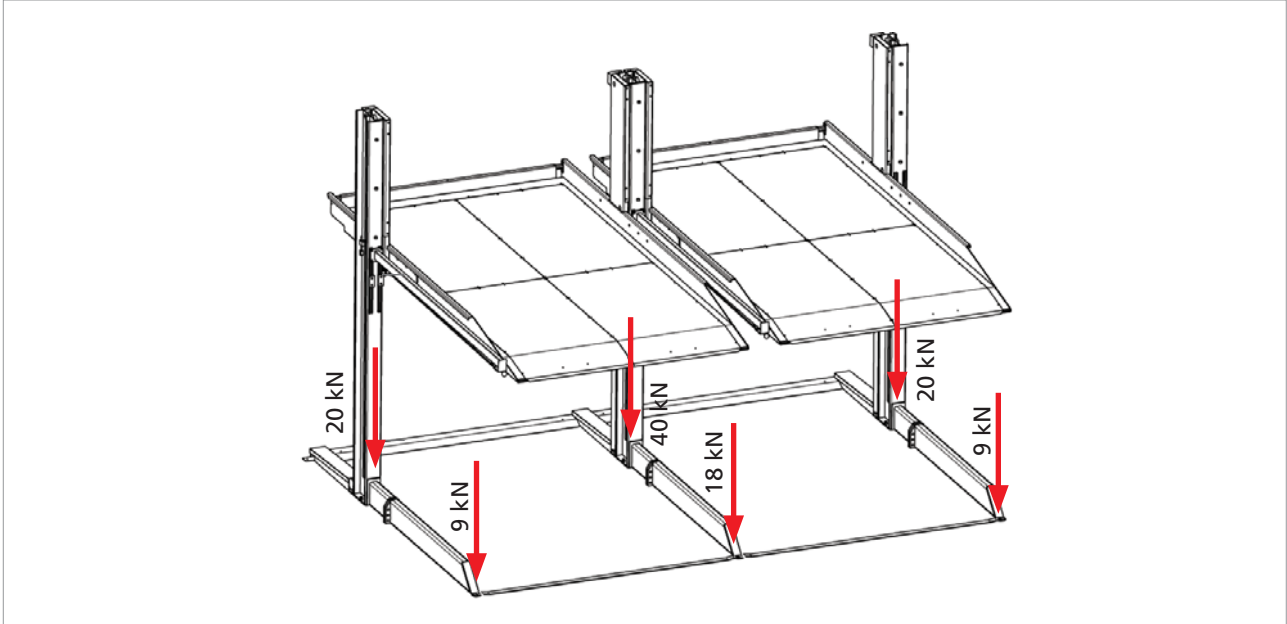

Functional description

